

FIGLEY STAMPING COMPANY
PHONE: 419-782-6896 FAX: 419-784-5121

1C1600 SERIES - C.R. STEEL WITH ZINC FINISH

THIS DRAWING AND INFORMATION IS THE PROPERTY OF FIGLEY STAMPING. IT IS LENT ON THE CONDITION THAT IT, IN WHOLE OR IN PART, SHALL NOT BE REPRODUCED, COPIED, LENT OR DISCLOSED TO ANY THIRD PARTY WITHOUT THE WRITTEN CONSENT OF FIGLEY STAMPING AND SHALL BE RETURNED TO FIGLEY STAMPING.

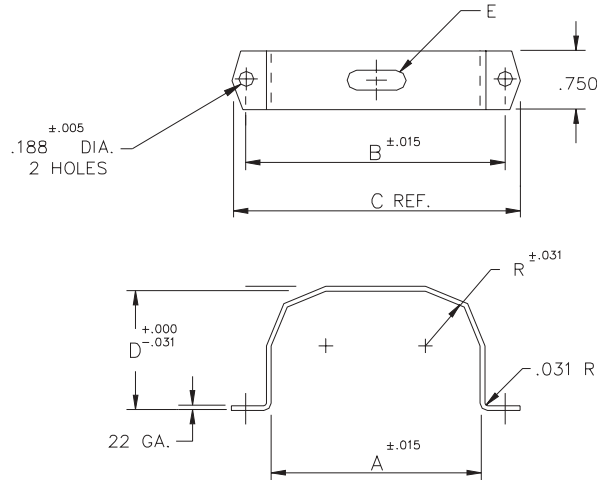

ALL DIMENSIONS TO BE MEASURED WHEN
BRACKET IS RIGIDLY HELD TO AVOID SPRINGBACK

PART NO.	DIM. "A"	DIM. "B"	DIM. "C"	DIM. "D"	DIM. "E"	DIM. "R"	CAN SIZE
1610	2.063	2.625	3.000	.922	.250 X .750	.500	1.000
1612	2.063	2.563	2.938	1.188	.250 X .750	.625	1.250
1613	2.063	2.563	2.938	2.375	.250 X .750	.625	
1614	2.063	2.563	2.938	1.250	NONE	.625	1.250
1615	2.813	3.313	3.813	1.703	NONE	.906	1.750
1616	2.813	3.313	3.688	1.703	NONE	.906	1.750
1617	2.781	3.313	3.688	1.719	NONE	.922	1.750
1618	2.625	3.125	3.500	1.438	NONE	.688	1.500
1619	2.813	3.313	3.688	1.781	NONE	.906	1.750
1620	2.563	3.063	3.438	1.625	NONE	.875	1.500
1621	2.813	3.563	3.938	1.797	NONE	.906	1.750
1622	3.531	4.000	4.500	1.719	NONE	.938	2.000
1623							
1624							
1625							
1626	3.563	4.000	4.438	1.906	NONE	.938	2.000
1627	3.547	4.063	4.438	1.781	NONE	.953	2.000
1628	3.500	4.250	4.625	1.813	NONE	.938	2.000
1629	3.656	4.063	4.563	1.969	NONE	.938	2.000
1630							

FINISH AVAILABLE: ZINC OR GALVANIZED (B)

E			TOLERANCES (EXCEPT AS NOTED) DECIMAL : .XX ± .XXX ± .031 ANGULAR : ±	 FIGLEY STAMPING COMPANY
D				
C				
B	6/8/93	S.J.		
A	1/16/92	NEP		
NO.	DATE	BY	ANGULAR :	MATL : 22 GA. C.R. STEEL OR GALV.
REVISIONS				DATE : 8/5/87 DR. BY : S.J.J. PART NO. : 1600P1

FIGLEY STAMPING COMPANY
PHONE: 419-782-6896 FAX: 419-784-5121

1C1600 SERIES - GALVANIZED MAT'L & LANCES

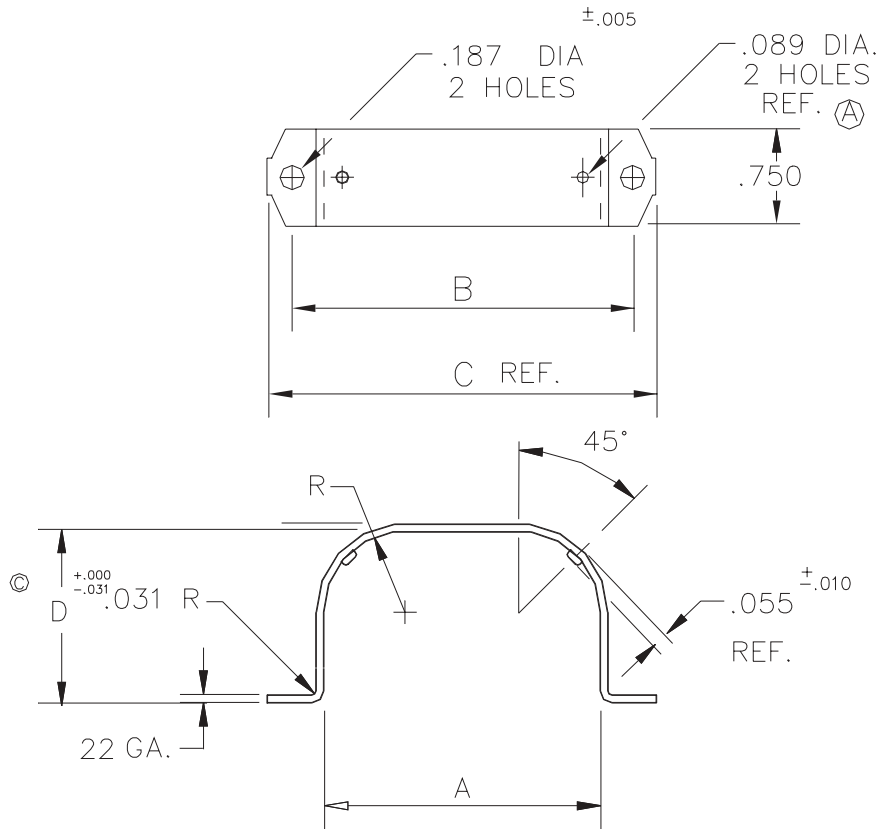

ALL DIMENSIONS TO BE MEASURED WHEN BRACKET IS RIGIDLY HELD TO AVOID SPRINGBACK.

PART NO.	DIM."A"	DIM."B"	DIM."C"	DIM."D"	DIM."R"	CASE SIZE
1612 GL	2.062	2.562	2.937	1.187	.625	1.250 OVAL
1617 GL	2.781	3.312	3.687	1.718	.921	1.750 OVAL
1627 GL	3.546	4.062	4.437	1.781	.953	2.000 OVAL
1614 GL	2.062	2.562	2.937	1.250	.625	

THIS DRAWING AND INFORMATION IS THE PROPERTY OF FIGLEY STAMPING. IT IS LENT ON THE CONDITION THAT IT, IN WHOLE OR IN PART, SHALL NOT BE REPRODUCED, COPIED, LENT OR DISCLOSED TO ANY THIRD PARTY WITHOUT THE WRITTEN CONSENT OF FIGLEY STAMPING AND SHALL BE RETURNED TO FIGLEY STAMPING.

E			TOLERANCES (EXCEPT AS NOTED) DECIMAL :	 FIGLEY STAMPING COMPANY
D				
C				
B	ECN 0146 10/20/95	S.J.J.	.XX ±	PART NAME: 1C1600 GL SERIES CAPACITOR CLAMP
A	12/2/91	NEP	.XXX ± .031	
NO.	DATE	BY	ANGULAR:	MATL:
	REVISIONS		±	22 GA. GALV. STEEL
				DATE: 8/6/87
				DR. BY: S.J.J.
				PART NO.: 1600GLP1

FIGLEY STAMPING COMPANY
PHONE: 419-782-6896 FAX: 419-784-5121

1C1611 SERIES - C.R. STEEL WITH ZINC FINISH OR GALVANIZED MAT'L

THIS DRAWING AND INFORMATION IS THE PROPERTY OF FIGLEY STAMPING. IT IS LENT ON THE CONDITION THAT IT, IN WHOLE OR IN PART, SHALL NOT BE REPRODUCED, COPIED, LENT OR DISCLOSED TO ANY THIRD PARTY WITHOUT THE WRITTEN CONSENT OF FIGLEY STAMPING AND SHALL BE RETURNED TO FIGLEY STAMPING.

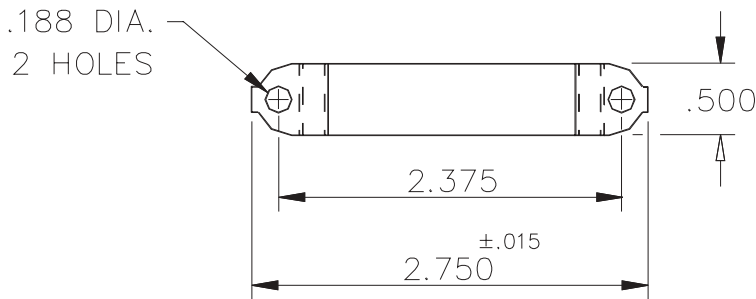
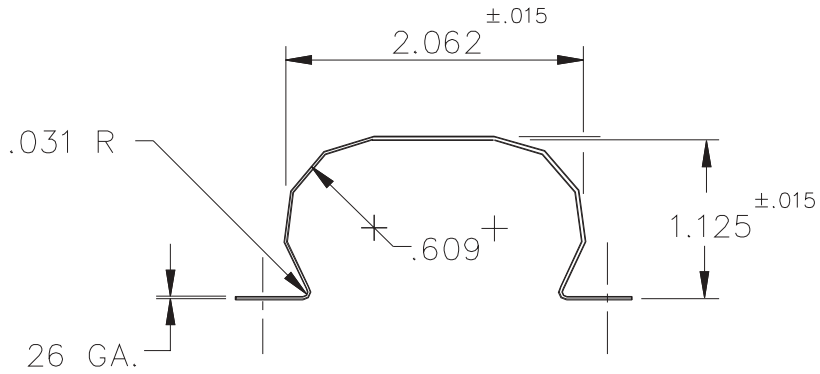

MAT'L NOTE: 25 GA. FOR C.R. STEEL + 26 GA. FOR GALV.
 FINISH AVAILABLE: GALVANIZED OR ZINC NO IMPRINT REQUIRED

ALL DIMENSIONS TO BE MEASURED WHEN
 BRACKET IS RIGIDLY HELD TO AVOID SPRINGBACK.

E			TOLERANCES (EXCEPT AS NOTED)	
D			DECIMAL :	
C			.XX ±	PART NAME:
B			.XXX ± .031	1C1611 CAPACITOR CLAMP
A	1/16/92	NEP	ANGULAR :	MATL:
NO.	DATE	BY	±	SEE NOTE ABOVE
REVISIONS				DATE: 8/6/87 DR. BY: S.J.J. PART NO.: 1611P1

FIGLEY STAMPING COMPANY
PHONE: 419-782-6896 FAX: 419-784-5121

1C1640 SERIES - GALVANIZED MAT'L

THIS DRAWING AND INFORMATION IS THE PROPERTY OF FIGLEY STAMPING. IT IS LENT ON THE CONDITION THAT IT, IN WHOLE OR IN PART, SHALL NOT BE REPRODUCED, COPIED, LENT OR DISCLOSED TO ANY THIRD PARTY WITHOUT THE WRITTEN CONSENT OF FIGLEY STAMPING AND SHALL BE RETURNED TO FIGLEY STAMPING.

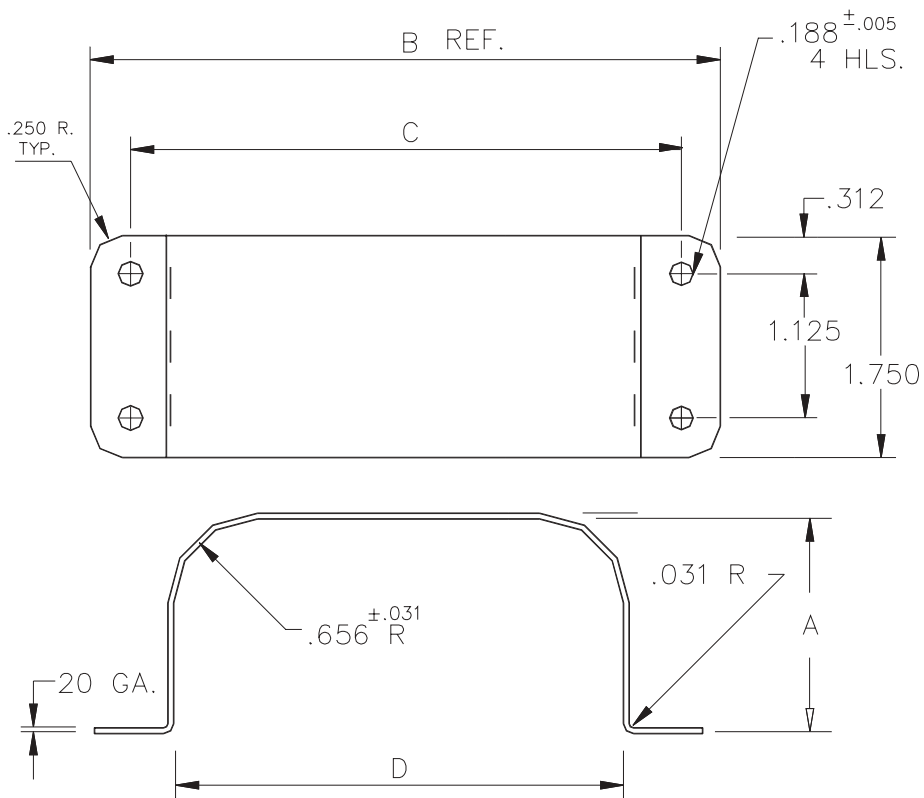

FINISH AVAILABLE: GALVANIZED

NO IMPRINT REQUIRED

ALL DIMENSIONS TO BE MEASURED WHEN BRACKET IS RIGIDLY HELD TO AVOID SPRINGBACK.

PART NO.	DIM."A"	DIM."B"	DIM."C"	DIM."D"	CASE SIZE
1644	2.687	5.734	5.109	4.484	LG. RECT.
1645	2.875	5.734	5.109	4.484	LG. RECT.
1646	4.406	4.031	3.406	2.781	LG. RECT.

E			TOLERANCES (EXCEPT AS NOTED) DECIMAL : .XX ± .XXX ± .031 ANGULAR : ±	 FIGLEY STAMPING COMPANY
D				
C				
B				
A	1/16/92	NEP		
NO.	DATE	BY	ANGULAR :	PART NAME: 1C1640G SERIES CAPACITOR CLAMP
REVISIONS			DATE: 3/10/88	DR. BY: S.J.J.
			MATL: 20 GA. X 1.750 GALV. STEEL	PART NO. : 1644P1

FIGLEY STAMPING COMPANY
PHONE: 419-782-6896 FAX: 419-784-5121

1C1640 SERIES - GALVANIZED MAT'L & LANCES

THIS DRAWING AND INFORMATION IS THE PROPERTY OF FIGLEY STAMPING. IT IS LENT ON THE CONDITION THAT IT, IN WHOLE OR IN PART, SHALL NOT BE REPRODUCED, COPIED, LENT OR DISCLOSED TO ANY THIRD PARTY WITHOUT THE WRITTEN CONSENT OF FIGLEY STAMPING AND SHALL BE RETURNED TO FIGLEY STAMPING.

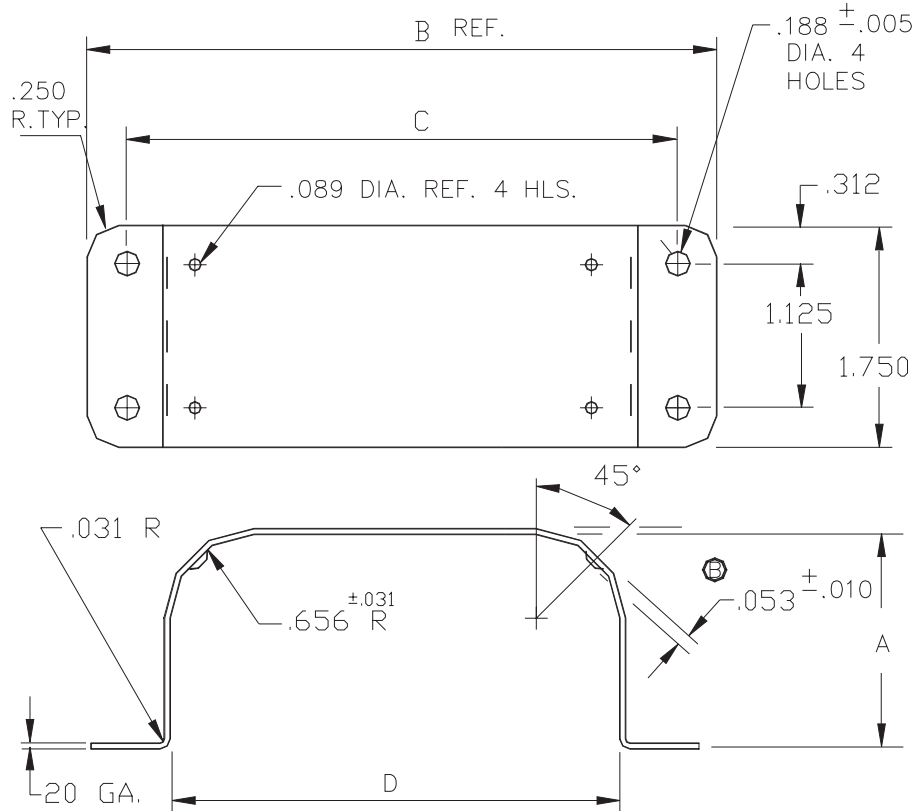

FINISH AVAILABLE: GALVANIZED

NO IMPRINT REQUIRED

ALL DIMENSIONS TO BE MEASURED WHEN BRACKET IS RIGIDLY HELD TO AVOID SPRINGBACK.

PART NO.	DIM."A"	DIM."B"	DIM."C"	DIM."D"	CASE SIZE
1644 GL	2.687	5.734	5.109	4.484	LG. RECT.
1645 GL	2.875	5.734	5.109	4.484	LG. RECT.
1646 GL	4.406	4.031	3.406	2.781	LG. RECT.
1647 GL	3.000	5.734	5.109	4.484	LG. RECT.

E			TOLERANCES (EXCEPT AS NOTED)	 FIGLEY STAMPING COMPANY
D				
C			DECIMAL :	PART NAME: 1C1640GL SERIES CAPACITOR BRKT.
B	ECN 0140 09/05/92	S.J.J.	.XX ±	
A	01/16/92	NEP	.XXX ± .031	
NO.	DATE	BY	ANGULAR :	MATL: 20 GA. X 1.750 GALV.
REVISIONS			±	DATE: 09/05/95 DR. BY: S.J.J. PART NO.: 1644GLP1

FIGLEY STAMPING COMPANY
PHONE: 419-782-6896 FAX: 419-784-5121

1C1682 SERIES - C.R. STEEL WITH ZINC FINISH OR GALVANIZED MAT'L

THIS DRAWING AND INFORMATION IS THE PROPERTY OF FIGLEY STAMPING. IT IS LENT ON THE CONDITION THAT IT, IN WHOLE OR IN PART, SHALL NOT BE REPRODUCED, COPIED, LENT OR DISCLOSED TO ANY THIRD PARTY WITHOUT THE WRITTEN CONSENT OF FIGLEY STAMPING AND SHALL BE RETURNED TO FIGLEY STAMPING.

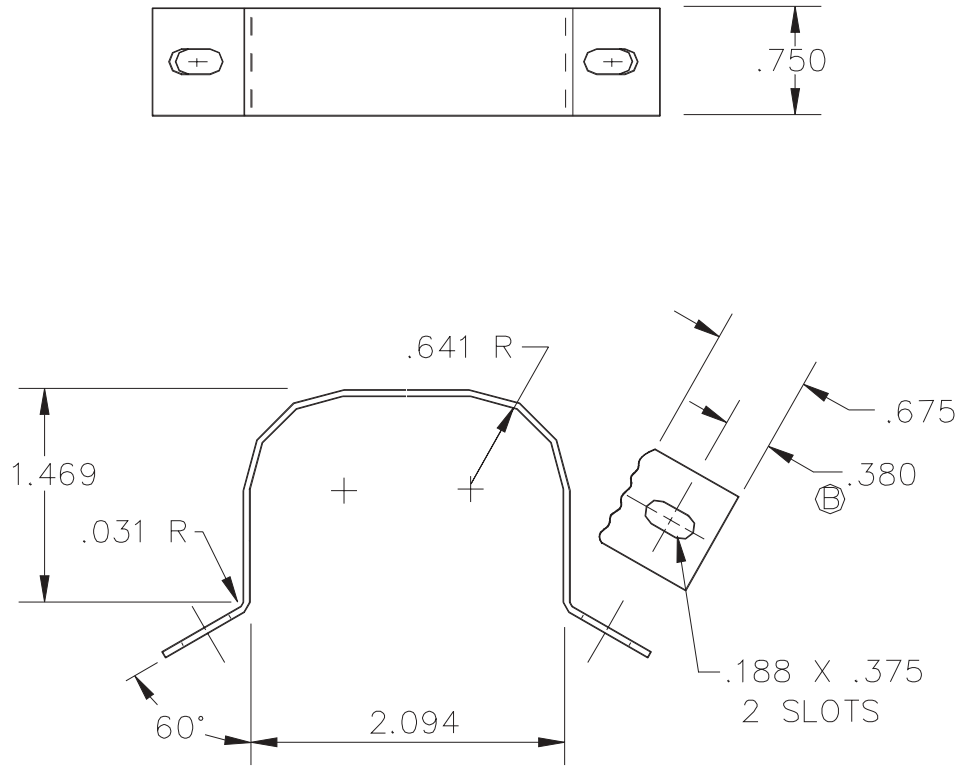

ALL DIMENSIONS TO BE MEASURED WHEN BRACKET IS RIGIDLY HELD TO AVOID SPRINGBACK

FINISH AVAILABLE: GALVANIZED OR ZINC PLATED

NO IMPRINT REQUIRED

E			TOLERANCES (EXCEPT AS NOTED)	
D			DECIMAL :	
C			.XX ±	
B	ECN 0353 11/13/98	L.J.B.	.XXX ± .031	PART NAME: 1C1682 CAPACITOR CLAMP
A	1/16/92	NEP		MATL: 22 GA. GALV. OR C.R. STEEL
NO.	DATE	BY	ANGULAR :	DATE: 3/10/88
	REVISIONS		±	DR. BY: S.J.J. PART NO.: 1682P1

FIGLEY STAMPING COMPANY
PHONE: 419-782-6896 FAX: 419-784-5121

1C1684 SERIES - C.R. STEEL WITH ZINC FINISH OR GALVANIZED MAT'L

THIS DRAWING AND INFORMATION IS THE PROPERTY OF FIGLEY STAMPING. IT IS LENT ON THE CONDITION THAT IT, IN WHOLE OR IN PART, SHALL NOT BE REPRODUCED, COPIED, LENT OR DISCLOSED TO ANY THIRD PARTY WITHOUT THE WRITTEN CONSENT OF FIGLEY STAMPING AND SHALL BE RETURNED TO FIGLEY STAMPING.

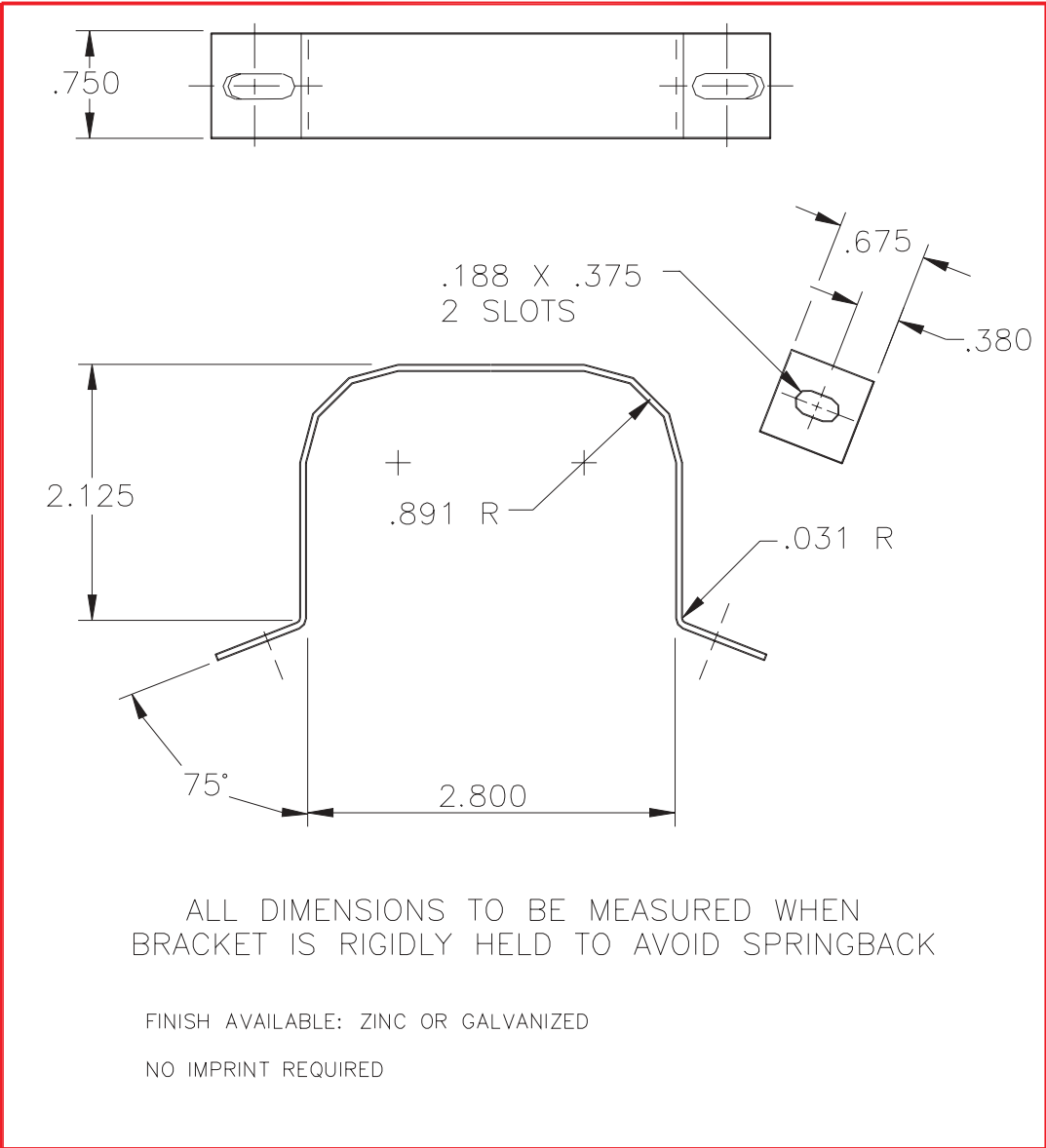

ALL DIMENSIONS TO BE MEASURED WHEN BRACKET IS RIGIDLY HELD TO AVOID SPRINGBACK

FINISH AVAILABLE: ZINC OR GALVANIZED

NO IMPRINT REQUIRED

E			TOLERANCES (EXCEPT AS NOTED)				
D			DECIMAL :				
C			.XX ±	PART NAME: 1C1684 CAPACITOR CLAMP			
B			.XXX ± .031				
A	12/18/91	NEP	ANGULAR :	MATL: SEE NOTE			
NO.	DATE	BY	±	DATE: 8/10/87	DR. BY: S.J.J.	PART NO.:	1684P1
REVISIONS							

FIGLEY STAMPING COMPANY
PHONE: 419-782-6896 FAX: 419-784-5121

1C1689 SERIES - C.R. STEEL WITH ZINC FINISH

THIS DRAWING AND INFORMATION IS THE PROPERTY OF FIGLEY STAMPING. IT IS LENT ON THE CONDITION THAT IT, IN WHOLE OR IN PART, SHALL NOT BE REPRODUCED, COPIED, LENT OR DISCLOSED TO ANY THIRD PARTY WITHOUT THE WRITTEN CONSENT OF FIGLEY STAMPING AND SHALL BE RETURNED TO FIGLEY STAMPING.

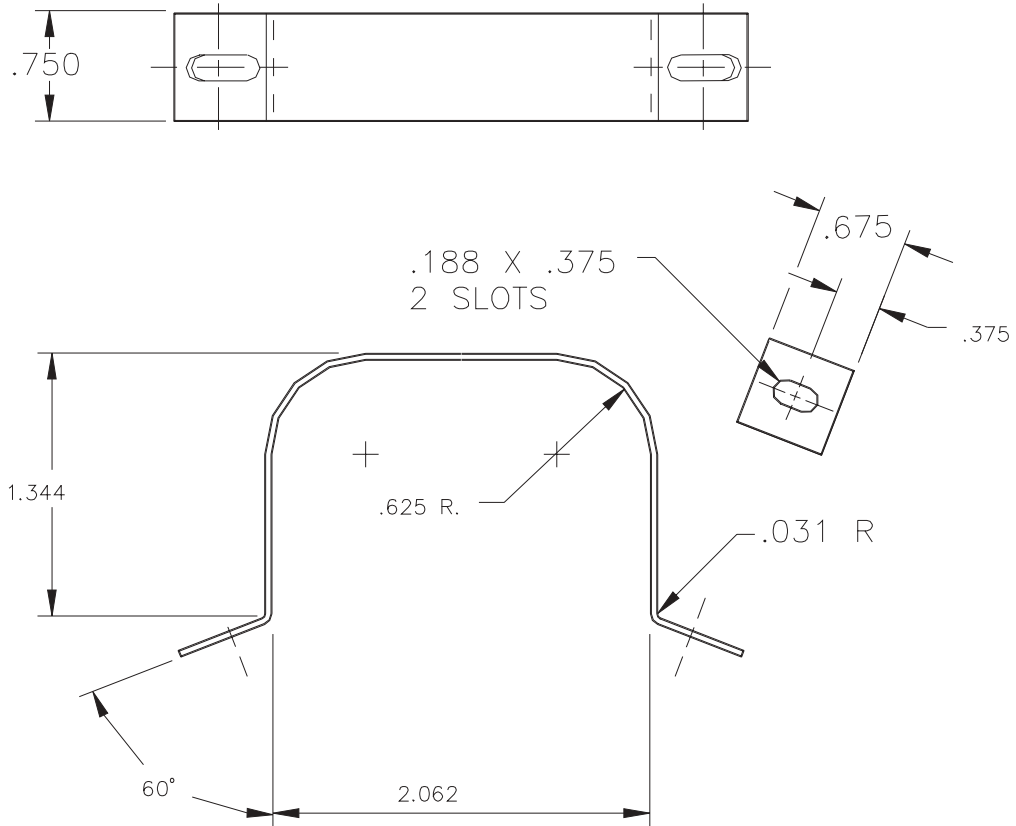

ALL DIMENSIONS TO BE MEASURED WHEN
BRACKET IS RIGIDLY HELD TO AVOID SPRINGBACK

FINISH AVAILABLE: ZINC

NO IMPRINT REQUIRED

E			TOLERANCES (EXCEPT AS NOTED) DECIMAL : .XX ± .XXX ± .031 ANGULAR : ±	 FIGLEY STAMPING COMPANY
D				
C				MATL: 22 GA. X .750 C.R. STEEL
B				DATE: 8/10/87 DR. BY: S.J.J. PART NO.: 1689Z1
A	12/18/91	NEP		
NO.	DATE	BY	REVISIONS	